

# *Advanced Computer Graphics*

## *Light and Color 1*

Matthias Teschner



# Outline

---

- Context
- Light
- Color

# Light

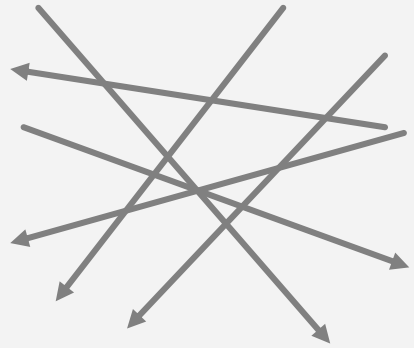

Light travels along rays

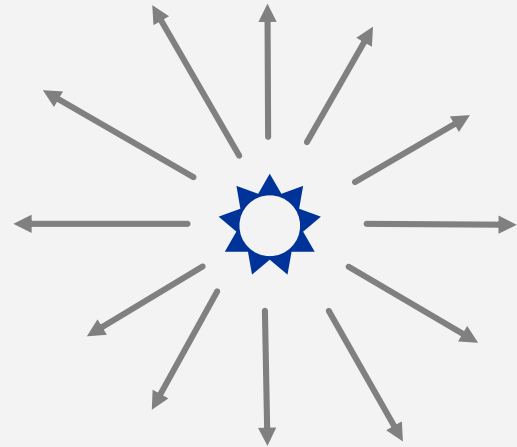

Light is emitted at light sources

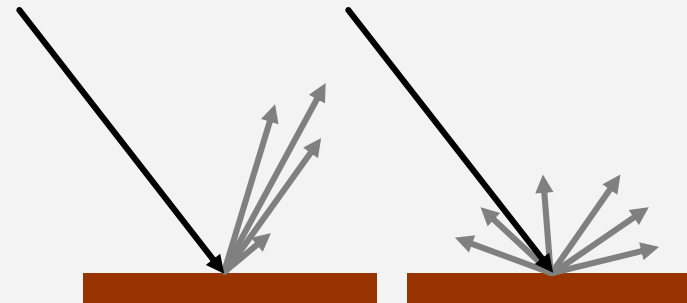

specular

diffuse

Incoming light / is absorbed and scattered at surfaces

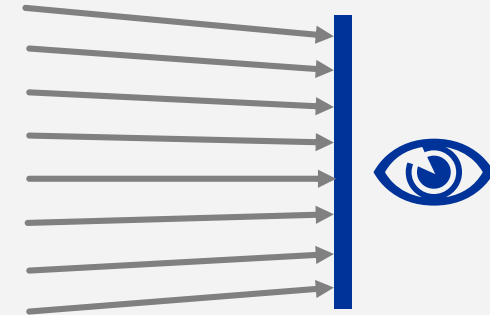

Cameras capture light

- How to quantify light transported along a ray?  $\Rightarrow$  Radiance
- How to quantify surface illumination?  $\Rightarrow$  Irradiance
- How to quantify light at a pixel?  $\Rightarrow$  Radiance

# Surface Reflection Properties

- How much incident light from a particular direction is reflected into a particular direction?

⇒ Bidirectional Reflectance Distribution Function BRDF  $f_r$

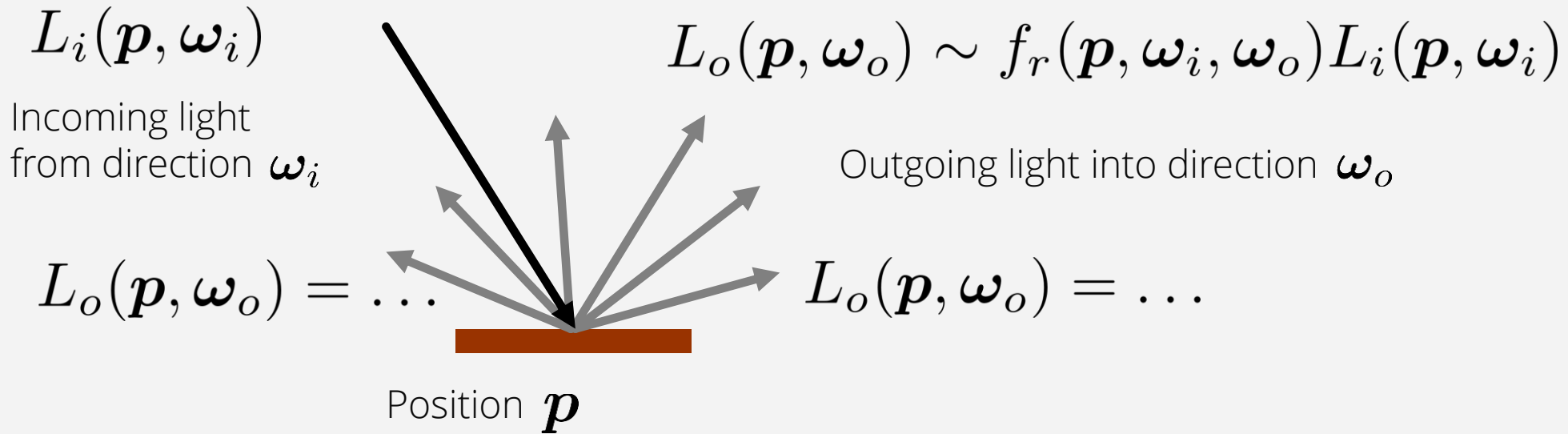

# Rendering Equation

- How to compute reflected light into a particular direction given incident light from all possible directions?  $\Rightarrow$  Rendering equation

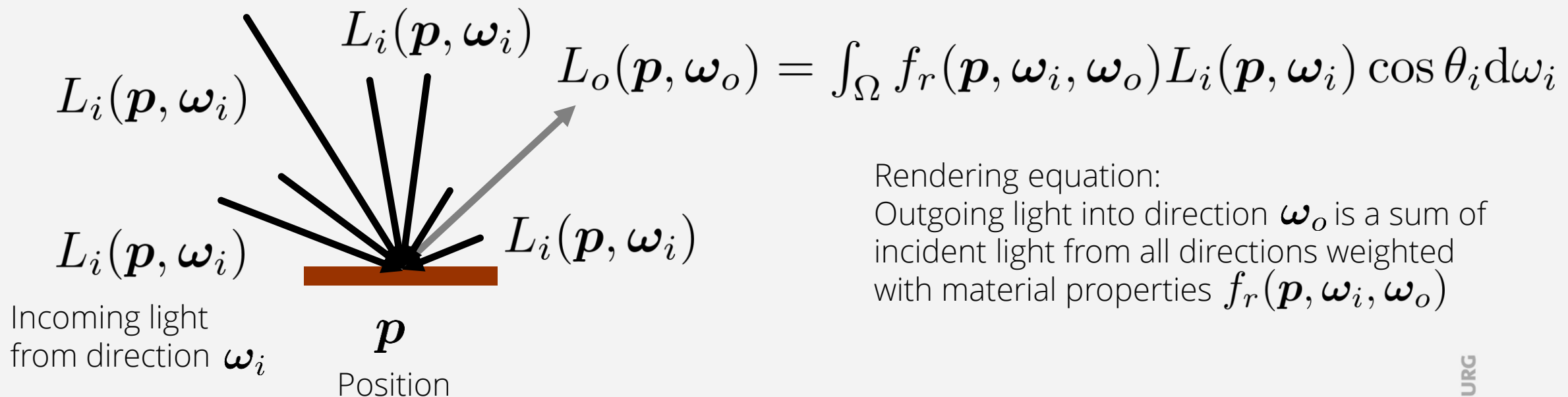

Rendering equation:  
Outgoing light into direction  $\boldsymbol{\omega}_o$  is a sum of incident light from all directions weighted with material properties  $f_r(\mathbf{p}, \boldsymbol{\omega}_i, \boldsymbol{\omega}_o)$

# *The Importance of Light Modeling*

---

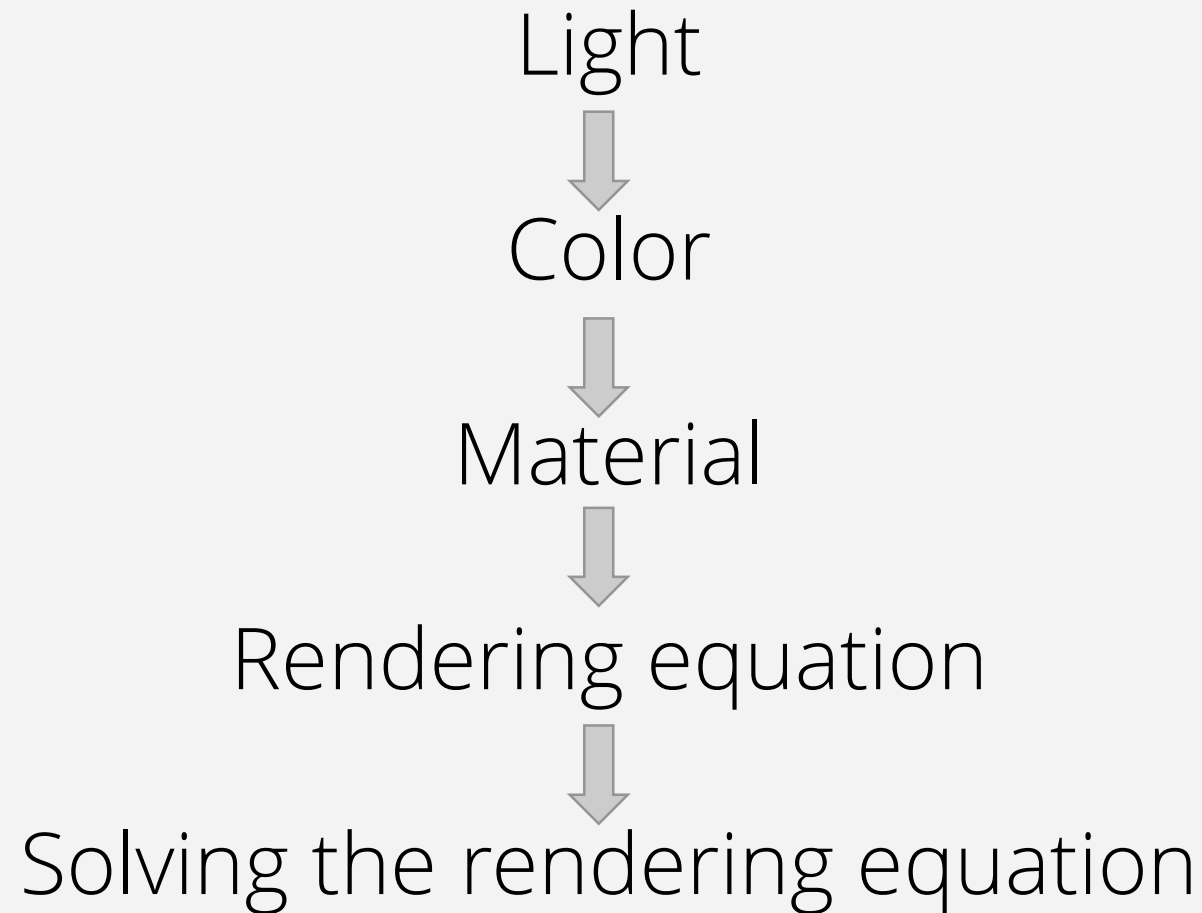

# Outline

---

- Context
- Light
- Color

# Light

---

- Radiation modeled with photons
  - Light particles
  - Energy parcels
  - Travel along a straight line at the speed of light
  - Characterized by a wavelength (perceived as color in the visible spectrum)

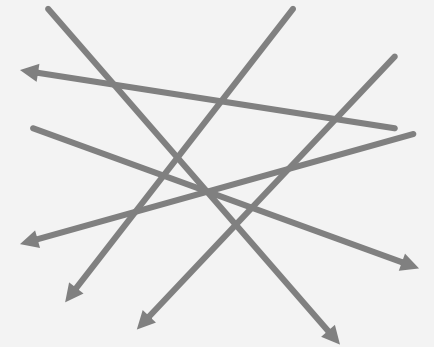

Photons travel  
along rays



# Quantifying Light

---

- Radiometric quantities characterize the propagation of electromagnetic radiation
  - Flux, irradiance, radiance
- Radiation with wavelengths between 390 nm and 750 nm is visible to humans  
(blue light  $\Rightarrow$  green light  $\Rightarrow$  red light)
- Radiometric quantities are represented by a spectrum
  - A distribution function of wavelengths
  - Amount of light at each wavelength interval

# Flux

---

- Radiant flux  $\Phi$ 
  - Power
  - Radiant energy, i.e. number of photons, per time

Flux is actually radiant energy per time.

$$\Phi = \frac{dQ}{dt}$$

As photons carry varying energy depending on their wavelength, number of photons per time is an approximation that improves the intuition behind flux.

# Flux Density

---

- Rate at which flux enters, leaves or passes an area

$$E = \frac{\Phi}{A}$$

- Describes strength of light with respect to a surface area (existing or virtual surface)
- No directional information

# Flux Density - Variants

- Irradiance  $E$  - incident / incoming flux per surface
- Radiosity  $B$  - outgoing flux (reflected plus emitted) per surface

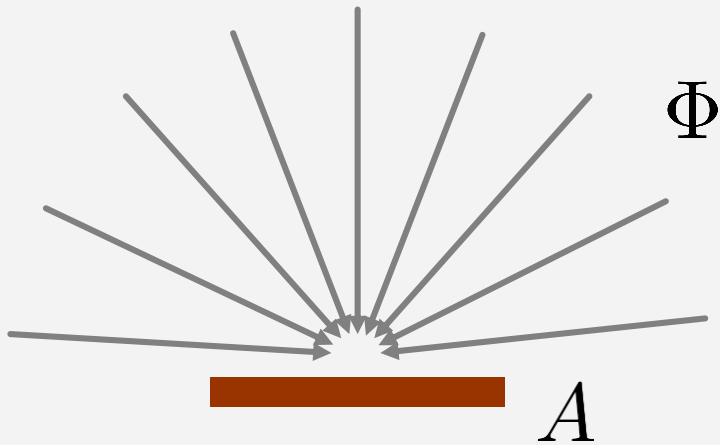

Irradiance – Incident flux per area

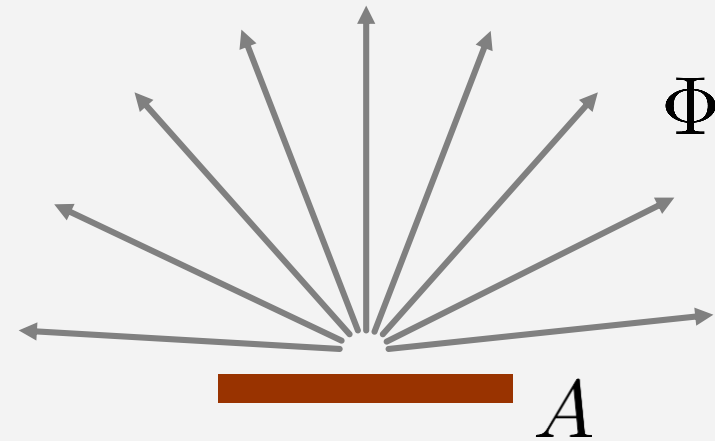

Radiosity – Outgoing flux per area

# Spatially Varying Flux Density

- Irradiance at a position  $E(\mathbf{x})$ ?
  - Issues: position with zero area, no flux per position
  - Solution: infinitesimals, differentials, small quantities
- Consider a small amount of flux  $d\Phi(\mathbf{x})$  incident to a small area  $dA(\mathbf{x})$  around position  $\mathbf{x}$
- For  $dA(\mathbf{x}) \rightarrow 0$ , we have  $d\Phi(\mathbf{x}) \rightarrow 0$ , and the ratio converges to the irradiance at  $\mathbf{x}$ :  $E(\mathbf{x}) = \frac{d\Phi(\mathbf{x})}{dA(\mathbf{x})}$

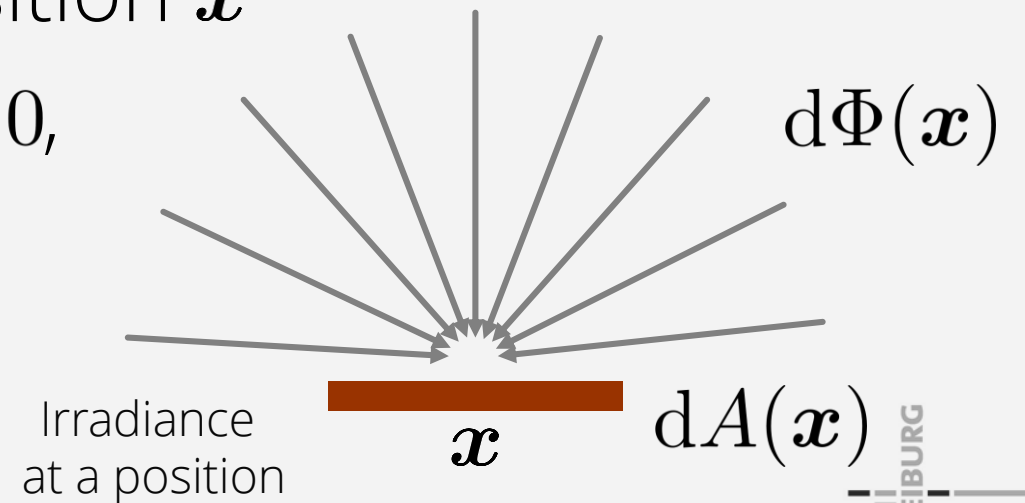

# Overall Flux Incident to a Surface

- Infinitesimally small amount of flux at a position

$$d\Phi(\mathbf{x}) = E(\mathbf{x})dA(\mathbf{x})$$

Conceptually,  $dA$  converges to zero, but we can still think of a small surface patch.

- Flux over an area

$$\Phi(A) = \int_{\text{Area}} E(\mathbf{x})dA(\mathbf{x}) \approx \sum_i E(\mathbf{x}_i)\Delta A(\mathbf{x}_i)$$

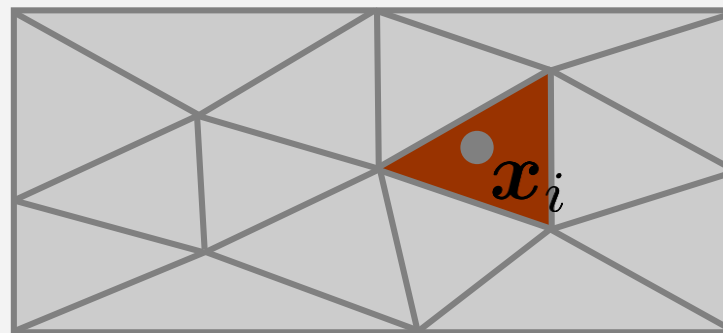
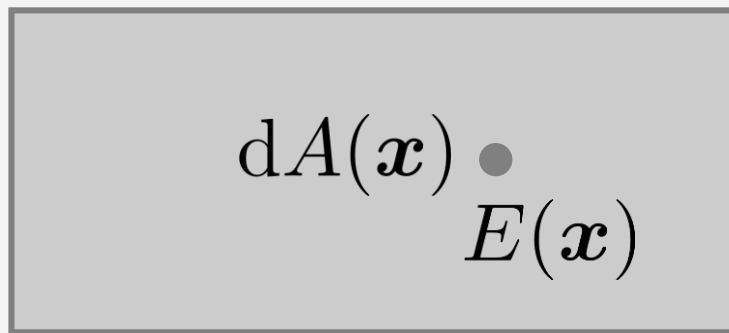

$$\Delta A(\mathbf{x}_i)$$

Area is discretized into surface patches with constant irradiance per patch.

$$E(\mathbf{x}_i)$$

# *Towards Directional Quantities*

---

- How to quantify light from / into a direction?
  - E.g., light towards viewer or towards surfaces
- Issue: Flux from / into a particular direction is zero
  - Analogous to flux per position
- Solution: Flux from / into a range of directions
  - Represented by angles in 2D
  - Represented by solid angles in 3D

# Solid Angle

- Area of a sphere surface divided by the squared sphere radius

$$\Omega = \frac{A}{r^2}$$

- E.g., solid angle of the entire sphere surface  $\Omega = \frac{4\pi r^2}{r^2} = 4\pi$

- Independent from the radius

- E.g., solid angle of a hemisphere

$$\Omega = \frac{1}{2} \frac{4\pi r^2}{r^2} = 2\pi$$

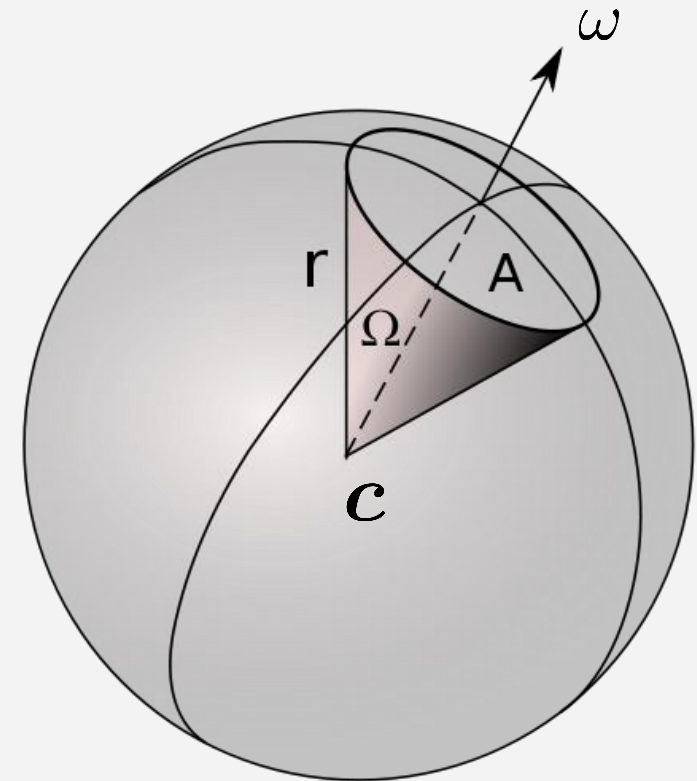

Wikipedia: Raumwinkel



# Solid Angle and Surface Area

- E.g., from which directions does a point  $\mathbf{c}$  receive light from an area light source?
- Solid angle of an arbitrary surface  $\Omega \approx \frac{A \cos \theta}{r^2}$

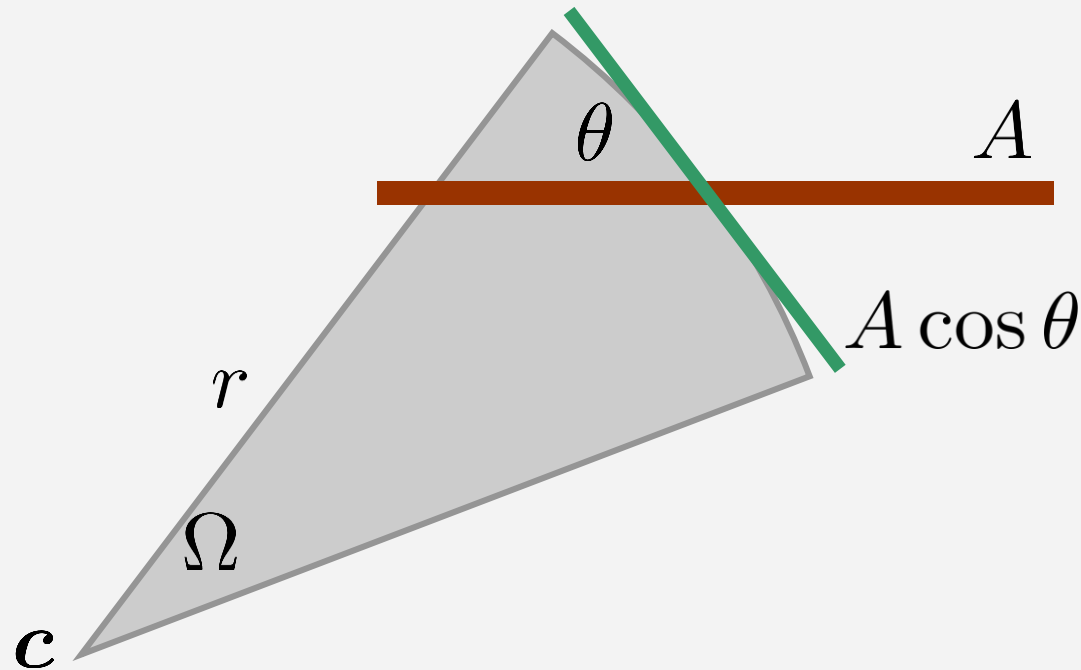

# Infinitesimal Solid Angle and Surface Area

- $\Omega \approx \frac{A \cos \theta}{r^2}$  is an approximation
- If an infinitesimally small area  $dA(\mathbf{x})$  at position  $\mathbf{x}$  converges to zero, then the solid angle  $d\omega$  also converges to zero and the relation  $d\omega = \frac{dA(\mathbf{x}) \cos \theta_{\mathbf{x}}}{r_{\mathbf{x}}^2}$  is correct in the limit

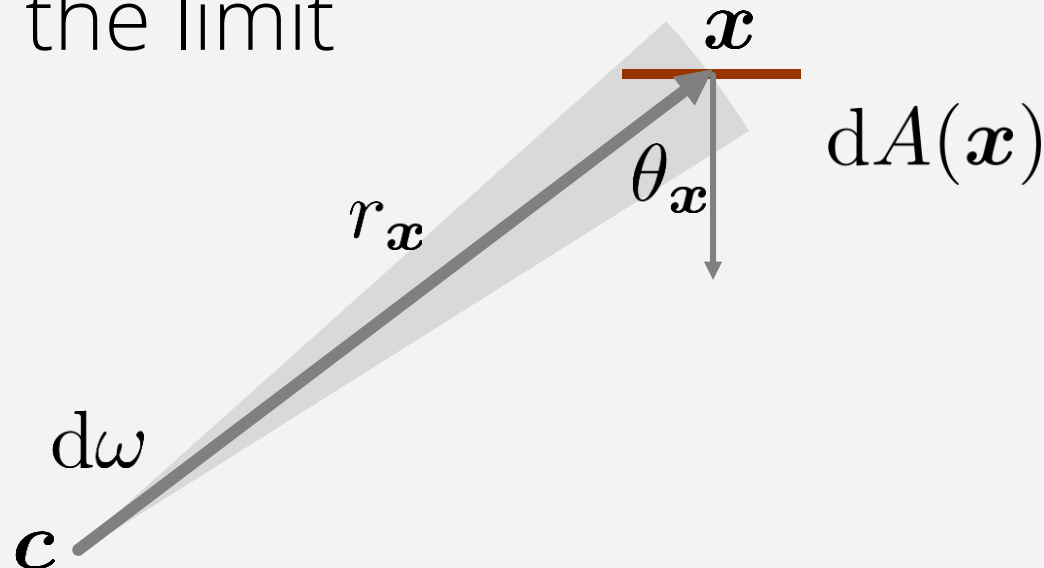

# Solid Angle Subtended by a Surface

- How big does an object appear in an image? From which solid angle does a point receive light from a light source?  $\Omega = \int_{\text{Surface}} \frac{\cos \theta_{\mathbf{x}}}{r_{\mathbf{x}}^2} dA(\mathbf{x}) \approx \sum_i \frac{\cos \theta_{\mathbf{x}_i}}{r_{\mathbf{x}_i}^2} A(\mathbf{x}_i)$

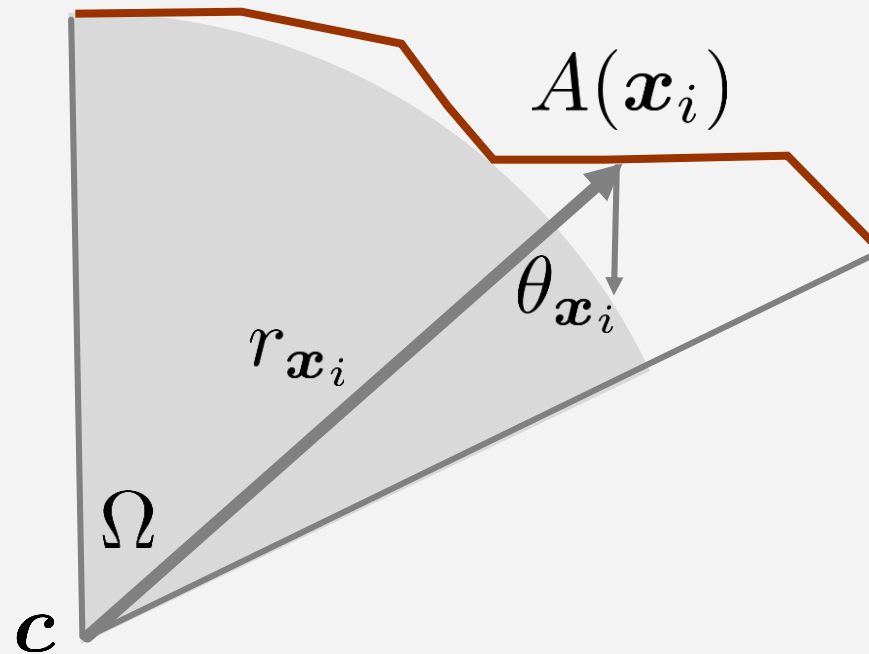
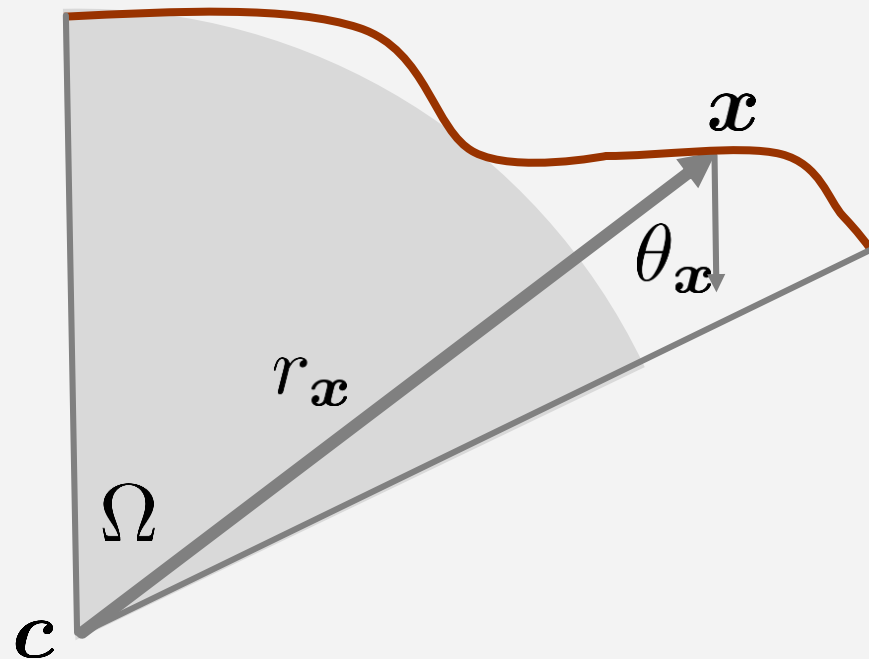

# Visibility Function

- Position  $\mathbf{x}$  only contributes to  $\int_{\text{Surface}} \frac{\cos \theta_{\mathbf{x}}}{r_{\mathbf{x}}^2} dA(\mathbf{x})$ , if it is visible from  $\mathbf{c}$
- Therefore,  
$$\Omega = \int_{\text{Surface}} V(\mathbf{c}, \mathbf{x}) \frac{\cos \theta_{\mathbf{x}}}{r_{\mathbf{x}}^2} dA(\mathbf{x})$$
with  $V(\mathbf{c}, \mathbf{x}) = 1$ , if  $\mathbf{x}$  is visible from  $\mathbf{c}$  and  $V(\mathbf{c}, \mathbf{x}) = 0$ , if  $\mathbf{x}$  is not visible from  $\mathbf{c}$

$$\begin{aligned}V(\mathbf{c}, \mathbf{x}_1) &= 1 \\V(\mathbf{c}, \mathbf{x}_2) &= 0 \\V(\mathbf{c}, \mathbf{x}_3) &= 0\end{aligned}$$

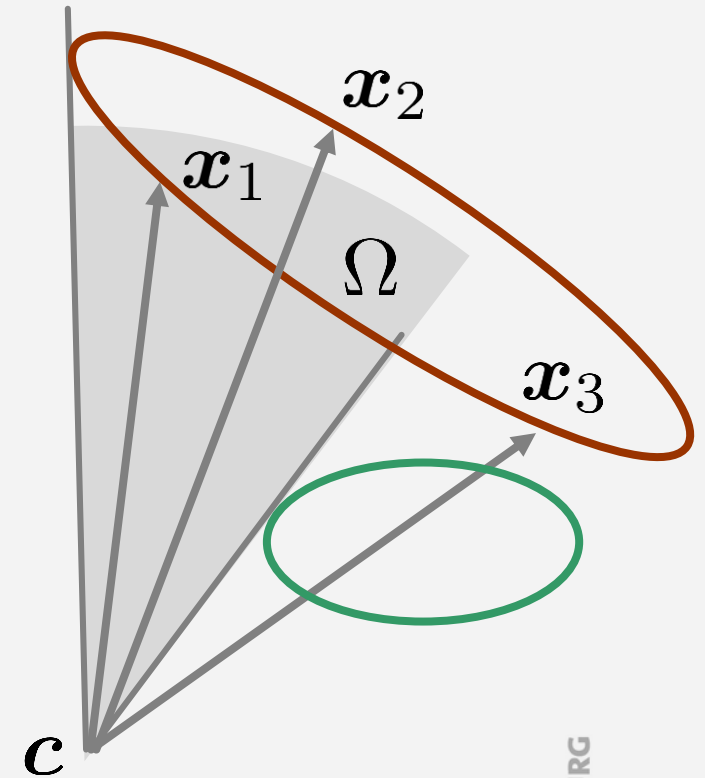

# Directional Flux per Area

- Flux per area per solid angle  $\frac{\Phi}{A \cdot \Omega}$ 
  - Photons per time that hit an area from directions within a solid angle
- Flux per projected area per solid angle  $\frac{\Phi}{A \cdot \cos \theta \cdot \Omega}$ 
  - How much flux travels through the grey area
  - Independent from sensor orientation

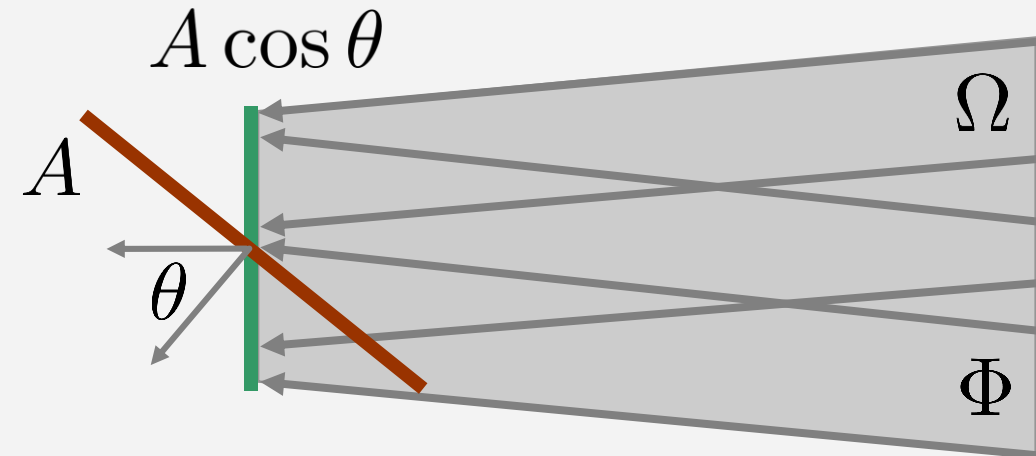
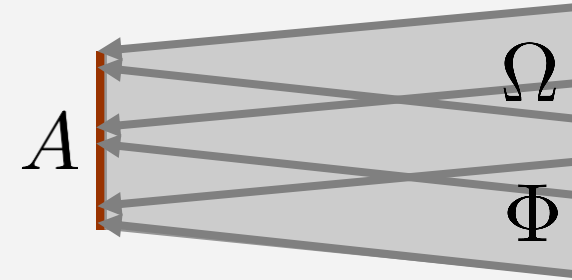

# Radiance

- If the area  $dA(\mathbf{x})$  around a position  $\mathbf{x}$  converges to zero and the solid angle  $d\omega$  around direction  $\omega$  converges to zero, then the flux  $d^2\Phi$  that hits (passes, is reflected from)  $dA(\mathbf{x})$  from (into) solid angle  $d\omega$  converges to zero and  $L(\mathbf{x}, \omega) = \frac{d^2\Phi}{dA \cdot \cos \theta \cdot d\omega}$  is the radiance at position  $\mathbf{x}$  from (into) direction  $\omega$

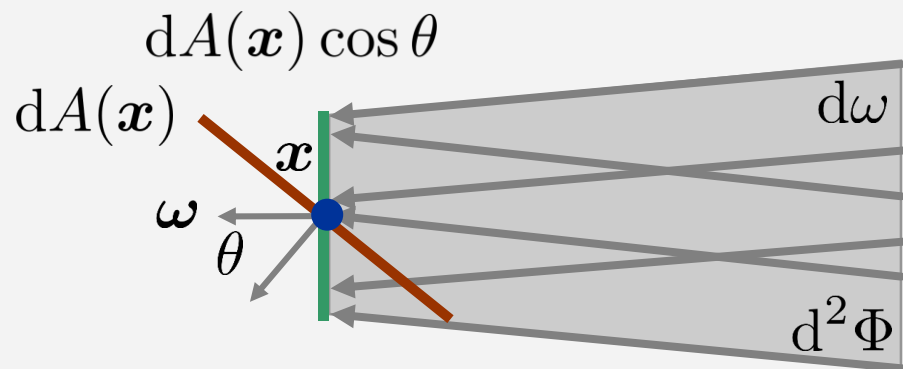

$L(\mathbf{x}, \omega)$  characterizes the flux that travels through position  $\mathbf{x}$  in direction  $\omega$ .

The notation  $d^2\Phi$  indicates that **two** integrations (over area **and** over solid angle) are required to get a non-infinitesimal value  $\Phi$ .

# Radiance at a Position in a Direction

- Actual setting

$$L(\mathbf{x}, \boldsymbol{\omega}) = \frac{d^2\Phi}{dA(\mathbf{x}) \cdot \cos\theta \cdot d\omega}$$

- Flux that is transported through an infinitesimally small cone

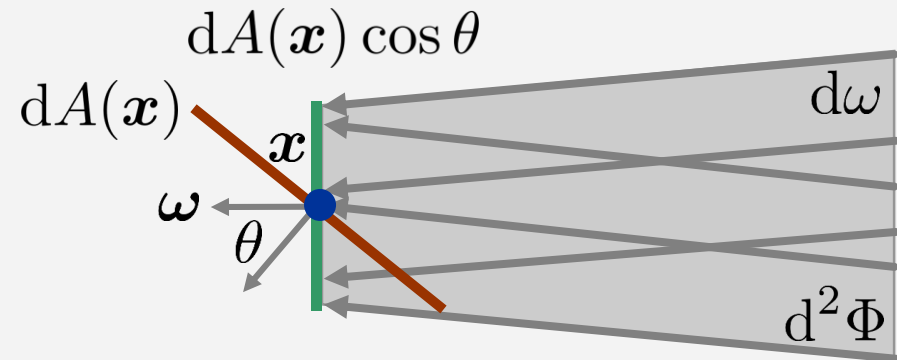

- Simplified notion

$$L(\mathbf{x}, \boldsymbol{\omega})$$

- Radiance  $L$  at position  $\mathbf{x}$  in direction  $\boldsymbol{\omega}$
- Flux that is transported along a ray



# *Flux Density and Radiance - Terms*

---

- Flux per area
  - Flux density
  - Incident / incoming flux density: Irradiance
  - Exitant / outgoing flux density: Radiosity
- Flux per projected area (orthogonal to flux direction) per solid angle
  - Radiance
  - Incident, outgoing radiance: Radiance



# Radiance and Oriented Surfaces

- Two areas  $dA_1, dA_2$  around positions  $\mathbf{x}_1, \mathbf{x}_2$  with  $\mathbf{x}_1 = \mathbf{x}_2$
- Angles between surface normal and flux direction  $\omega$ :  
 $\theta_1 = 0, \theta_2 \neq 0$

- Radiance at  $\mathbf{x}_1$ :

$$L(\mathbf{x}_1, \omega) = \frac{d^2 \Phi}{dA_1 \cdot \cos \theta_1 \cdot d\omega} = \frac{d^2 \Phi}{dA_1 \cdot d\omega}$$

- Radiance at  $\mathbf{x}_2$ :

$$L(\mathbf{x}_2, \omega) = \frac{d^2 \Phi}{dA_2 \cdot \cos \theta_2 \cdot d\omega} = \frac{d^2 \Phi}{dA_1 \cdot d\omega}$$

$$L(\mathbf{x}_1, \omega) = L(\mathbf{x}_2, \omega)$$

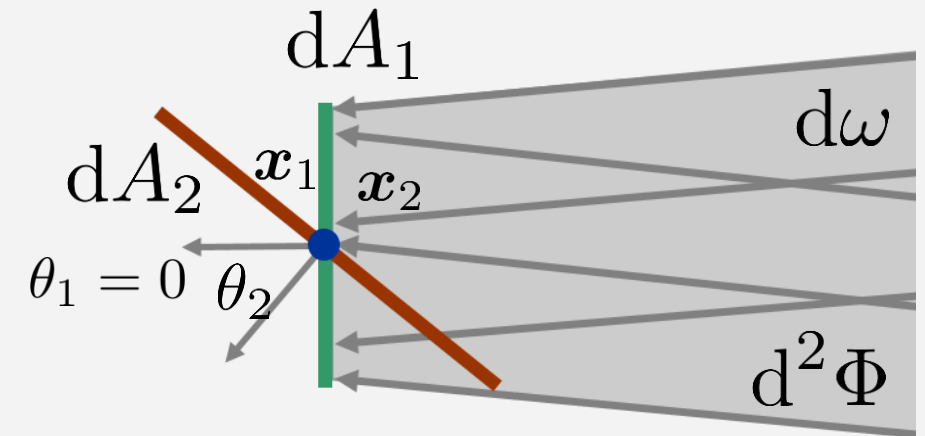

Radiance describes the flux within the grey area independent from the plane (sensor) orientation.

# Irradiance and Oriented Surfaces

- Irradiance at  $\mathbf{x}_1$ :  $E(\mathbf{x}_1) = \frac{d\Phi}{dA_1}$
- Irradiance at  $\mathbf{x}_2$ :  $E(\mathbf{x}_2) = \frac{d\Phi}{dA_2}$

$$dA_2 = \frac{dA_1}{\cos \theta_2} \Rightarrow E(\mathbf{x}_2) = \cos \theta_2 \cdot E(\mathbf{x}_1)$$

$$dA^\perp = dA_1 \cos \theta_1 = dA_2 \cos \theta_2 = dA_i \cos \theta_i$$

$$\Rightarrow E^\perp = \frac{E(\mathbf{x}_1)}{\cos \theta_1} = \frac{E(\mathbf{x}_2)}{\cos \theta_2} = \frac{E(\mathbf{x}_i)}{\cos \theta_i} \quad \text{i denotes an arbitrary orientation.}$$

- Lambert's Cosine Law
  - Irradiance on a surface is proportional to the cosine of the angle between surface normal and flux direction

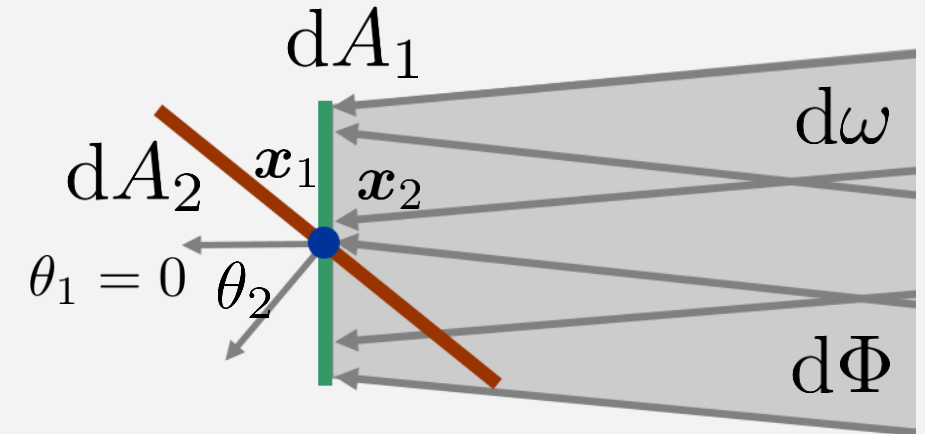

Irradiance describes the effect of the flux within the grey area onto a surface. I.e., the orientation of the surface with respect to the flux direction matters.

# Lambert's Cosine Law

- Angle between surface normal and light source direction influences the surface brightness

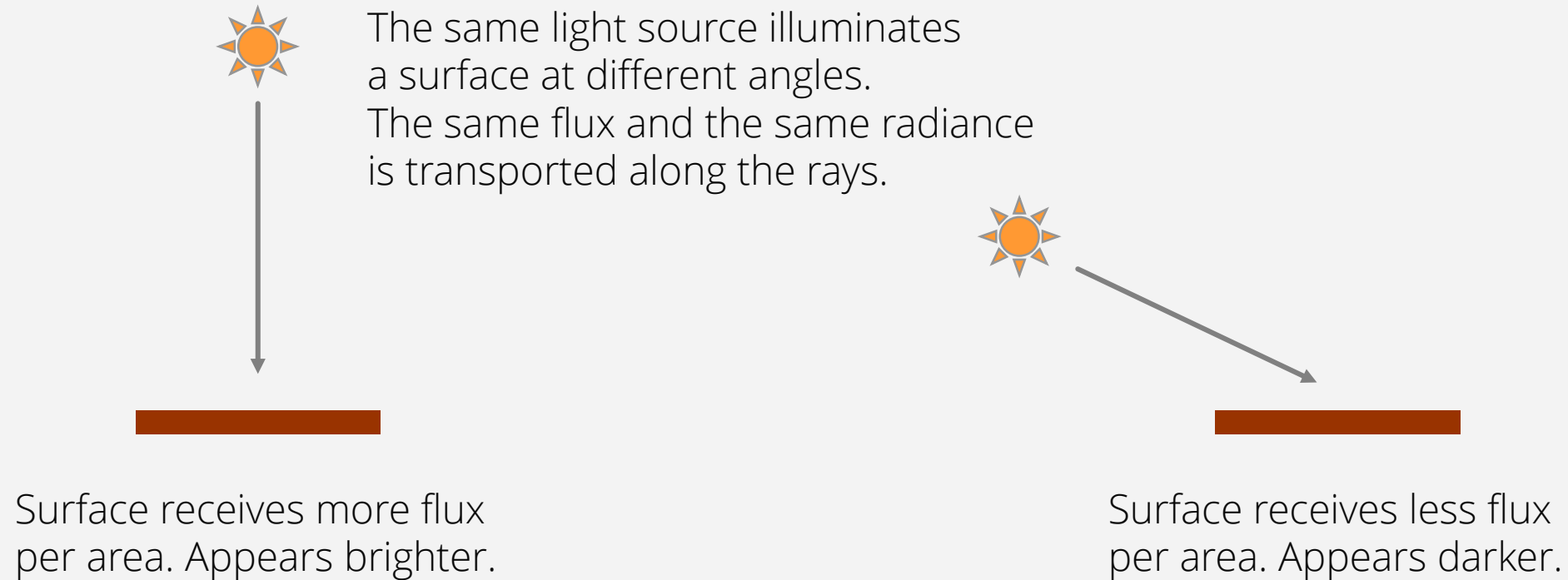

# Discussion

- Radiance characterizes the flux that is transported between infinitesimally small surface areas (along rays)
- Irradiance characterizes the effect of this flux at these surface areas

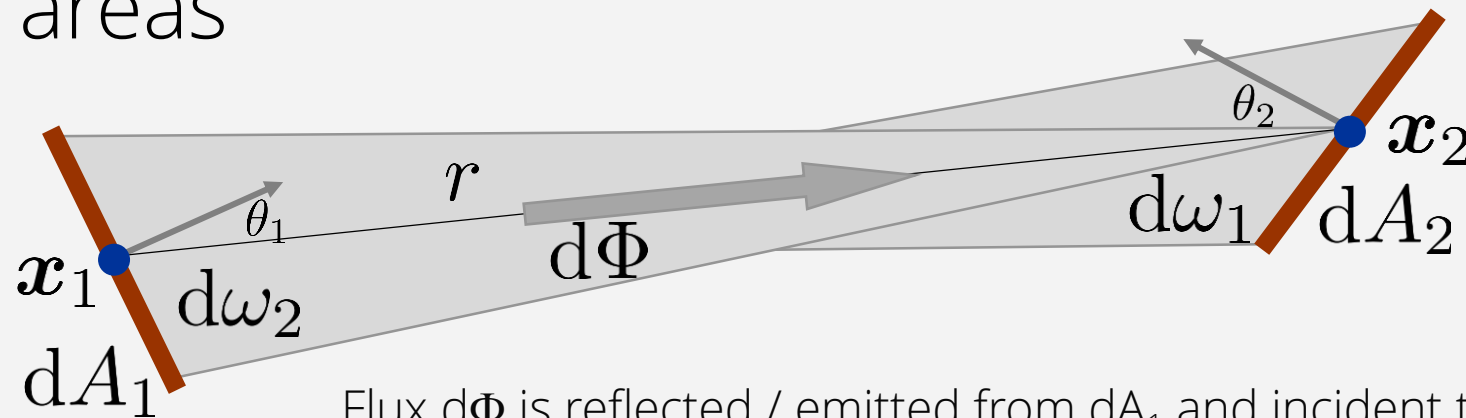

Flux  $d\Phi$  is reflected / emitted from  $dA_1$  and incident to  $dA_2$ .  
Distance from  $\mathbf{x}_1$  to  $\mathbf{x}_2$  is  $r$ .  
Angles between flux direction and surface normal are  $\theta_1$  and  $\theta_2$ .  
Size of  $dA_1$  seen from  $\mathbf{x}_2$  is the solid angle  $d\omega_2$ .  $d\omega_1$  analogous.

# Discussion – Conservation of Radiance

- Radiosity at  $\mathbf{x}_1$ :  $B(\mathbf{x}_1) = \frac{d\Phi}{dA_1}$
- Irradiance at  $\mathbf{x}_2$ :  $E(\mathbf{x}_2) = \frac{d\Phi}{dA_2} \neq B(\mathbf{x}_1)$
- Radiance at  $\mathbf{x}_1$ :

$$L(\mathbf{x}_1, \boldsymbol{\omega}_1) = \frac{d^2\Phi}{dA_1 \cdot \cos \theta_1 \cdot d\omega_1} \quad d\omega_1 = \frac{dA_2 \cdot \cos \theta_2}{r^2}$$

$$L(\mathbf{x}_1, \boldsymbol{\omega}_1) = \frac{r^2 \cdot d^2\Phi}{dA_1 \cdot \cos \theta_1 \cdot dA_2 \cdot \cos \theta_2}$$

- Radiance at  $\mathbf{x}_2$ :

$$L(\mathbf{x}_2, \boldsymbol{\omega}_2) = \frac{d^2\Phi}{dA_2 \cdot \cos \theta_2 \cdot d\omega_2} \quad d\omega_2 = \frac{dA_1 \cdot \cos \theta_1}{r^2}$$

$$L(\mathbf{x}_2, \boldsymbol{\omega}_2) = \frac{r^2 \cdot d^2\Phi}{dA_1 \cdot \cos \theta_1 \cdot dA_2 \cdot \cos \theta_2} = L(\mathbf{x}_1, \boldsymbol{\omega}_1)$$

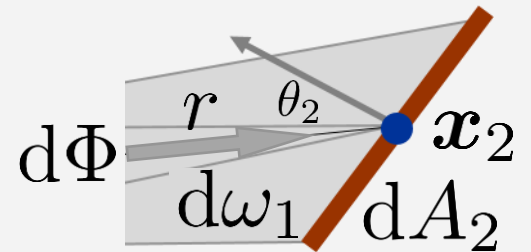
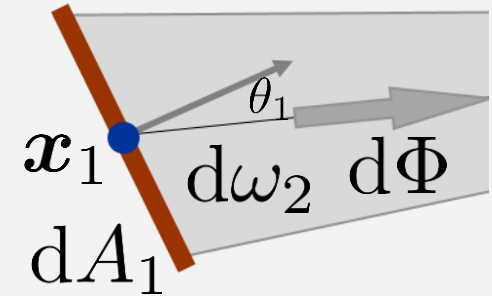

Conservation of radiance.  
Radiance describes flux transported along a ray.

# Discussion – Inverse Square Law

- Irradiance at an illuminated surface decreases quadratically with the distance from a light source
  - Surfaces appear darker with growing distance from light sources

- Flux generated at A, arriving at  $A_1$  and  $A_2$ :  $L \cdot A \cdot \Omega$

- Areas

$$A_1 \sim \Omega \cdot r_1^2 \quad A_2 \sim \Omega \cdot r_2^2$$

- Irradiances

$$E_1 \sim \frac{\Phi}{A_1} = \frac{L \cdot A \cdot \Omega}{\Omega \cdot r_1^2} \quad E_2 \sim \frac{\Phi}{A_2} = \frac{L \cdot A \cdot \Omega}{\Omega \cdot r_2^2} \quad E \sim \frac{1}{r^2}$$

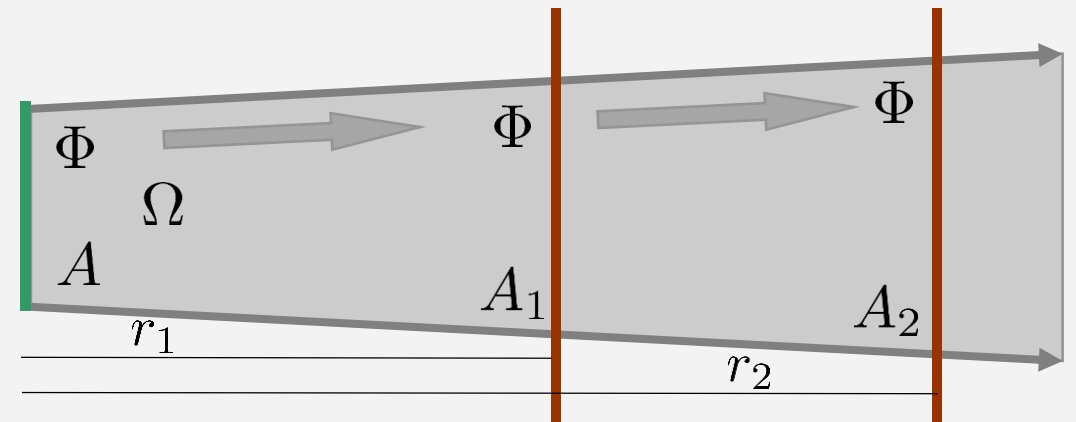

All planes are orthogonal to  $\omega$ .  
Thus,  $\cos \theta = 1$  for all planes.

# Sensor Model

- Pinhole camera model
  - Sensor elements with a small area receive flux from a small solid angle, i.e. radiance
- Radiance
  - Is measured by sensors
  - Is computed in computer-generated images

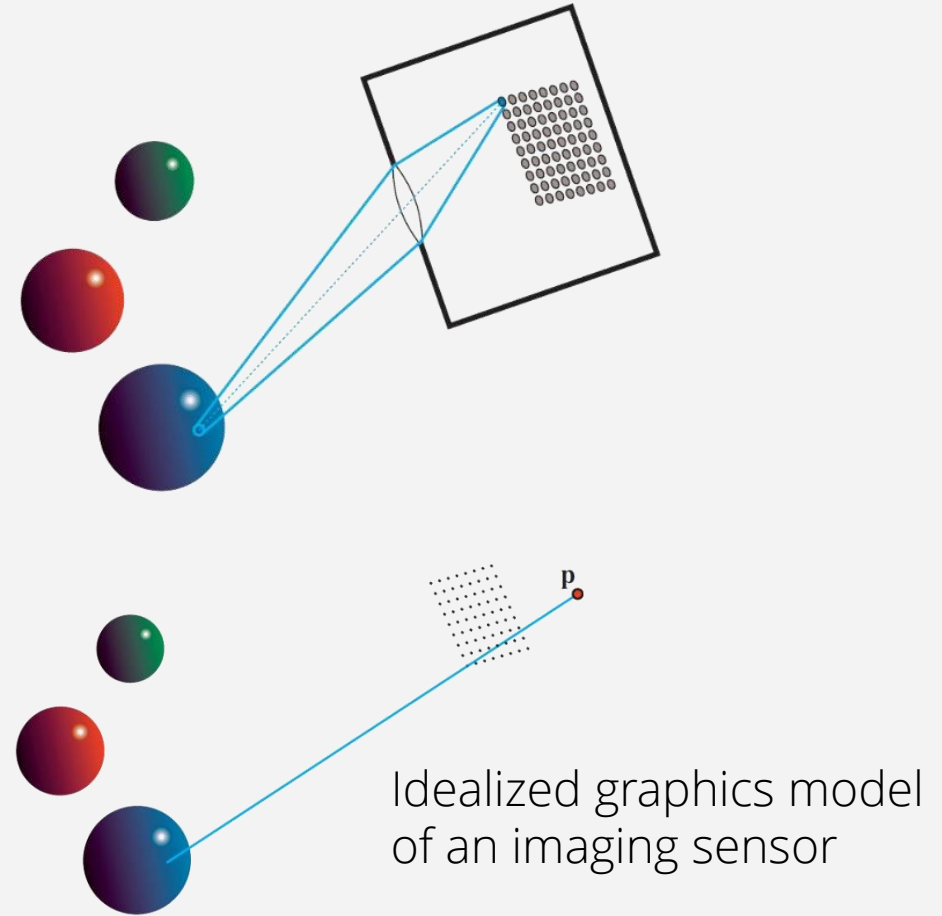

[Akenine-Möller et al.]

# Discussion – Sensors Measure Radiance

- Surface brightness is independent from the distance between surface and viewer / camera / sensor
  - Flux at A decreases quadratically with distance  $r$ , if  $A_1$  moves, e.g., from distance  $r_1$  to  $r_2$
  - The area visible at A grows quadratically with distance  $r$ . The sensor at A receives flux from a quadratically growing area
  - Both effects cancel, if the same radiance over the areas  $A_1$  and  $A_2$  is reflected onto A

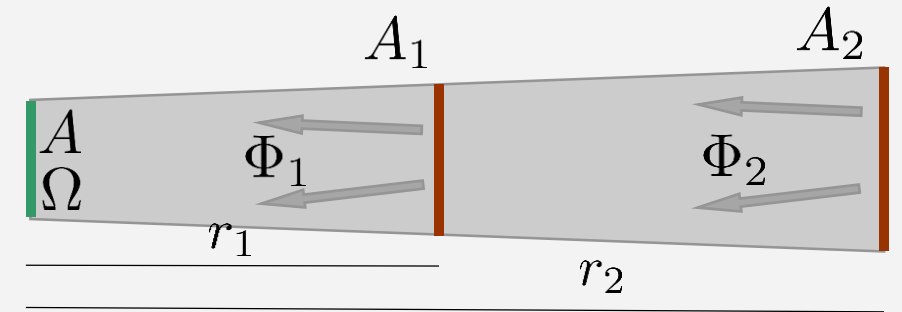



# Discussion – Sensors Measure Radiance

- Surface brightness is independent from the distance between surface and viewer / camera / sensor
  - Not true, if a surface does not cover a sensor element, e.g., object appears smaller than a pixel
  - Flux at sensor area  $A$  decreases quadratically with distance  $r$
  - Radiance decreases quadratically with  $r$

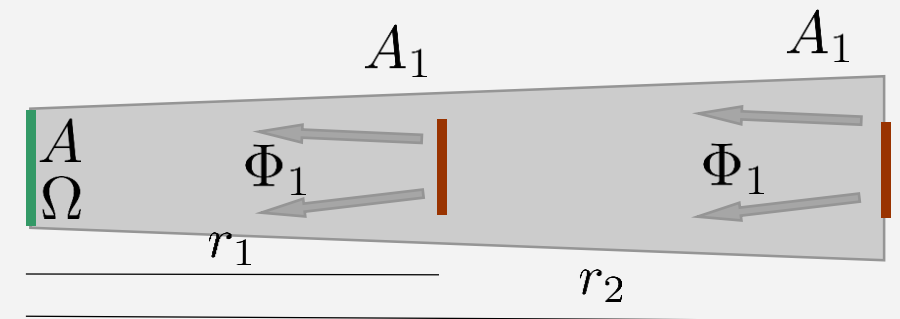

# Discussion – Irradiance and Radiance

---

- Illumination strength at a surface can be characterized by irradiance (flux per area)
  - Depends quadratically on the distance between surface and light source
- Illumination strength at a sensor element can be characterized by radiance (flux per area per solid angle)
  - Does not depend on the distance between surface and sensor

# Discussion – Irradiance and Radiance

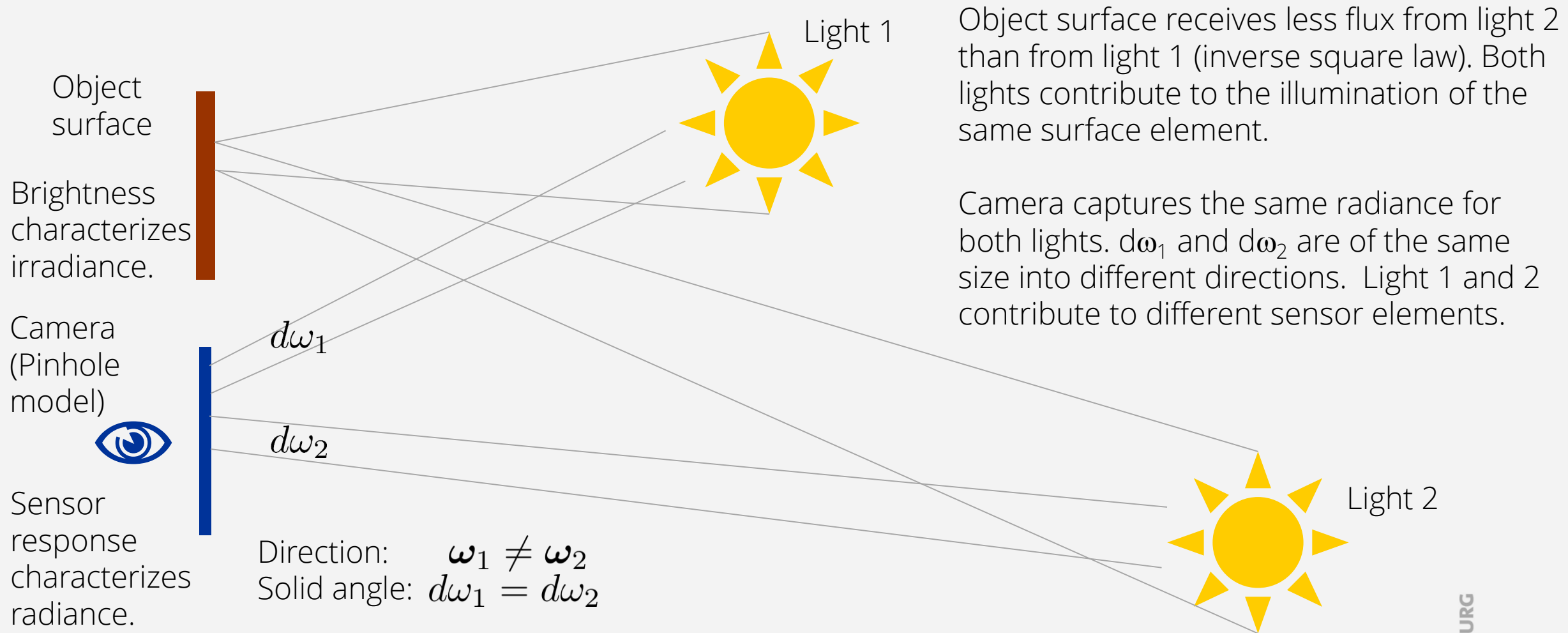

# *Radiometric vs. Photometric Quantities*

---

- Radiometric quantities describe all types of radiation
  - Preferred in graphics research
  - E.g., flux, irradiance, radiosity, radiance
- Photometric quantities describe visible radiation weighted with the sensitivity of the human eye
  - E.g., luminous flux [lumen], illuminance [lux], luminous exitance [lux], luminance [candela / m<sup>2</sup>]

# Summary

---

- Flux describes the number of photons per time
  - More precisely photon energy per time
- Irradiance and radiosity describe the flux into, through or from a surface per area
  - Irradiance describes the illumination of surfaces
- Radiance describes the flow at a direction into or from a surface orthogonal to that direction per area per solid angle
  - Radiance is measured by sensors

# *Advanced Computer Graphics*

## *Light and Color 2*

Matthias Teschner



# Outline

---

- Context
- Light
- Color

# Introduction

- Light consists of a set of photons
- Photons are characterized by a wavelength within the visible spectrum from 390 nm to 750 nm
- The distribution of wavelengths within this set is referred to as spectral power distribution (spectrum)
- Spectra are perceived as colors

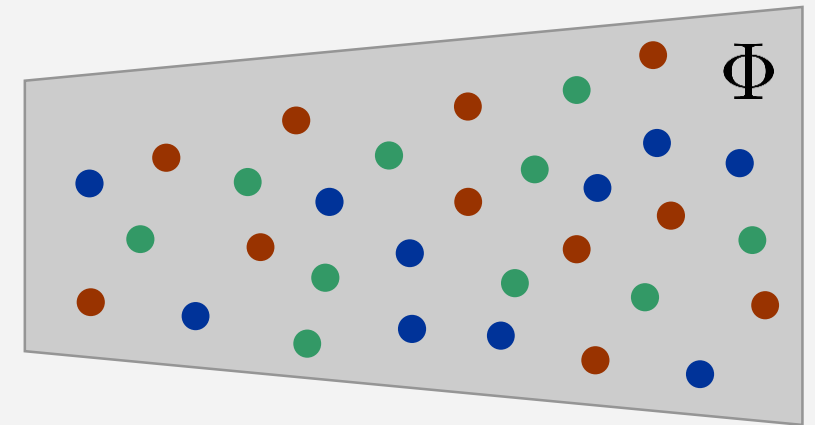



# Spectral Quantities

- Flux, flux density and radiance depend on wavelength

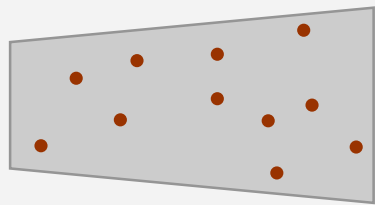

$$\Phi_\lambda(\lambda_1)$$

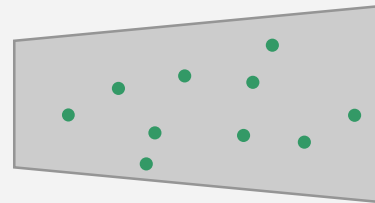

$$\Phi_\lambda(\lambda_2)$$

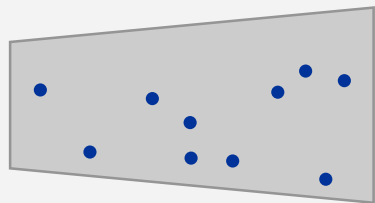

$$\Phi_\lambda(\lambda_3)$$

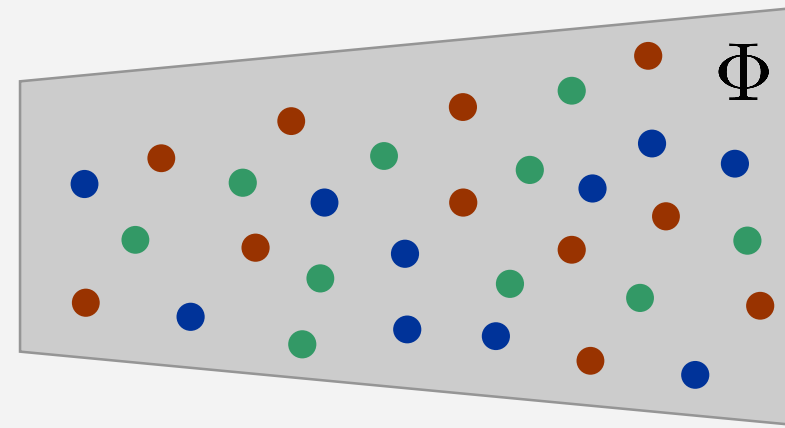

$$\Phi$$

$$\begin{aligned}\Phi &= \int_{\text{VisibleSpectrum}} \Phi_\lambda(\lambda) d\lambda \\ &\approx \sum_i \Phi_\lambda(\lambda_i) \Delta\lambda_i\end{aligned}$$

Photons with a wavelength in a range  $\Delta\lambda_i$  around  $\lambda_i$ .

# Visible Spectrum

- If the spectrum consists of a dominant wavelength, humans perceive a "rainbow" color (monochromatic)



- If all wavelengths are equally distributed, humans perceive gray, ranging from black to white (achromatic)
- Colors "mixed from rainbow colors" are chromatic

This spectrum corresponds to a ripe brown banana under white light (reflectance).

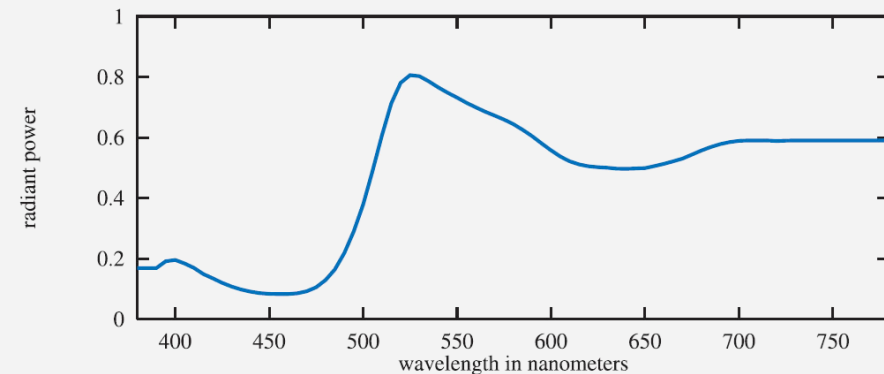

[Akenine-Möller et al.]

# Spectral Power Distribution / Reflectance

- A spectrum can describe, e.g.,
  - The wavelength distribution within flux
  - The reflectance or absorbance of flux at surfaces

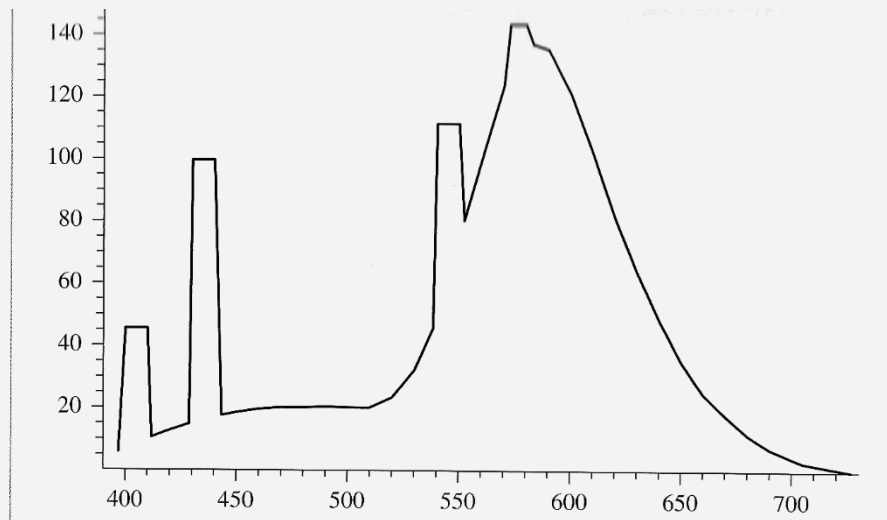

Spectral power distribution  
of a light source

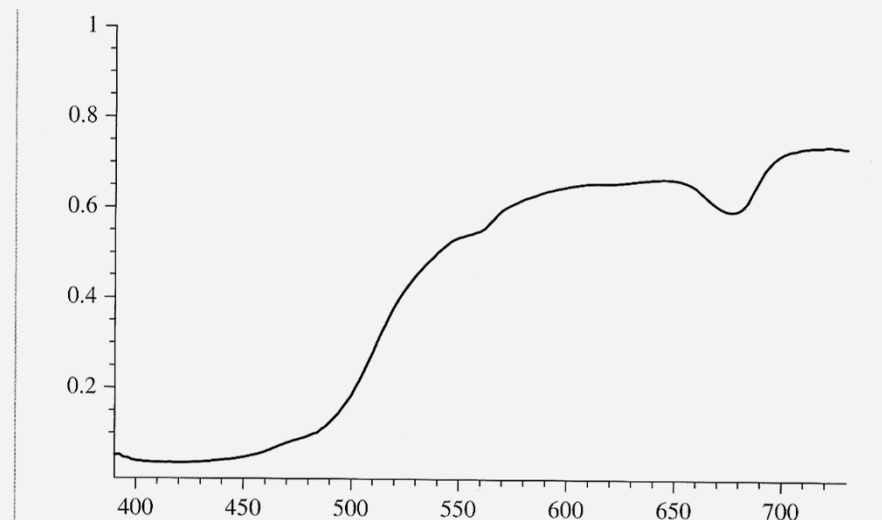

Reflectance of lemon skin

[Pharr, Humphreys]

# Representing a Spectrum

- Spectrum

$$\Phi = \int_{\text{VisibleSpectrum}} \Phi_{\lambda}(\lambda) d\lambda$$

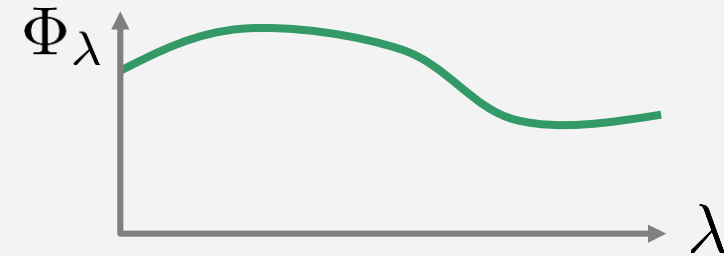

- Uniform samples, e.g.

$$\Phi = \sum_{i \in \text{red, green, blue}} \Delta\lambda \cdot \Phi_i$$

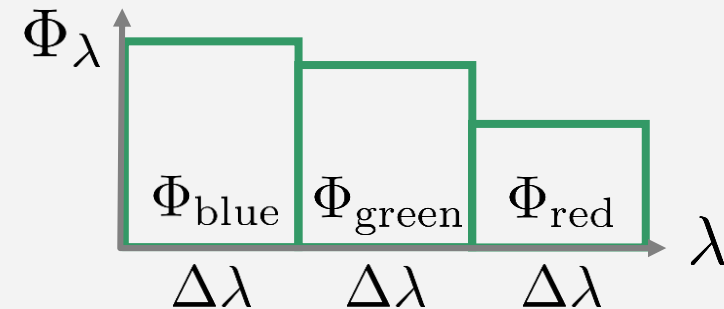

- Non-uniform samples, e.g.,

$$\Phi = \sum_i \Delta\lambda_i \cdot \Phi_i$$

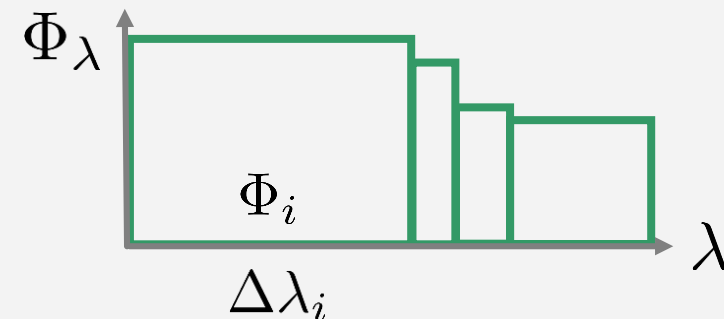

# Flux vs. Spectral Flux

---

- Color (spectrum) is typically represented with  $\Phi_{\text{red}}, \Phi_{\text{green}}, \Phi_{\text{blue}}$  (RGB values, spectral flux values)
- Raytracing concepts are described with  $\Phi$  (flux)
  - Can be flux
  - Can also be interpreted as a spectral flux vector
- E.g.,  $L(\mathbf{x}, \boldsymbol{\omega}) = \frac{d^2\Phi}{dA \cdot \cos\theta \cdot d\omega}$  typically refers to

$$(L_{\text{red}}, L_{\text{green}}, L_{\text{blue}})(\mathbf{x}, \boldsymbol{\omega}) = \frac{d^2(\Phi_{\text{red}}, \Phi_{\text{green}}, \Phi_{\text{blue}})}{dA \cdot \cos\theta \cdot d\omega}$$

# Color Perception

- Perceived color is the radiation spectrum weighted with absorbance spectra (sensitivity) of the eye

Photopic vision during daylight

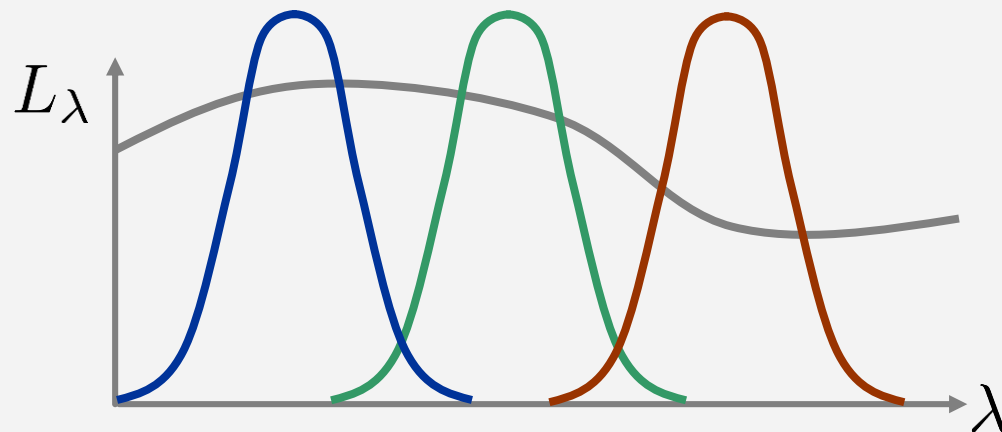

Radiation spectrum and absorbance spectra of human cone cells (Zapfen). Cone cells absorb (are sensitive to) blue, green, red radiation.

Scotopic vision during night

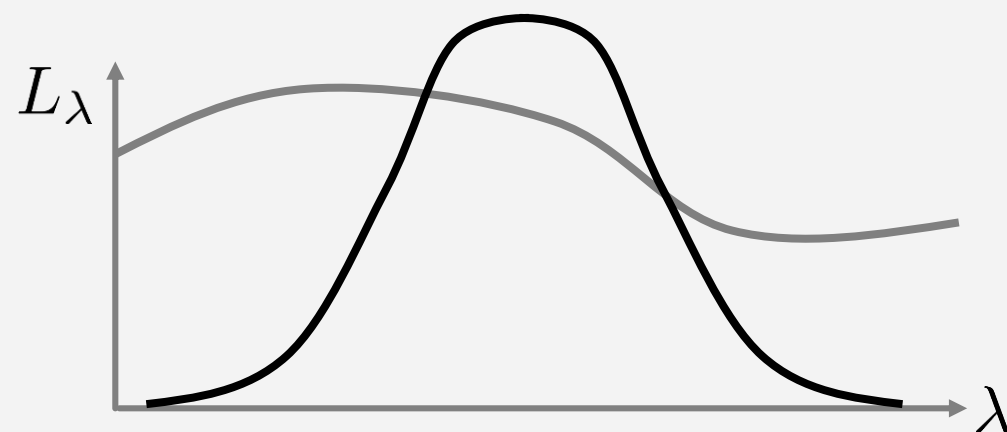

Radiation spectrum and absorbance spectrum of human rod cells (Stäbchen). Rod cells absorb a wider range of visible radiation.

# Color Perception

- Basis functions map from infinite-dimensional space to low-dimensional space (3D in daylight, 1D at night)

Photopic vision during daylight

$$X = \int_{\lambda} L_{\lambda}(\lambda) x(\lambda) d\lambda$$

$$Y = \int_{\lambda} L_{\lambda}(\lambda) y(\lambda) d\lambda$$

$$Z = \int_{\lambda} L_{\lambda}(\lambda) z(\lambda) d\lambda$$

$x(\lambda)$ ,  $y(\lambda)$ ,  $z(\lambda)$  are the absorbance spectra of human cone cells.

Scotopic vision during night

$$I = \int_{\lambda} L_{\lambda}(\lambda) i(\lambda) d\lambda$$

$i(\lambda)$  is the absorbance spectrum of a rod cell.

- In daylight, three cone signals ( $X$ ,  $Y$ ,  $Z$ ) are interpreted by the brain as color

# Color Perception

- Is a complex phenomenon

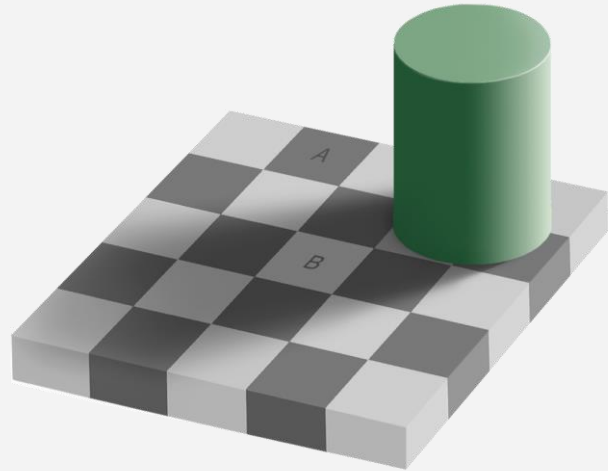

A and B are of the same color / brightness.



Perception (partially) adapts to changing illumination.

Wikipedia: Color constancy

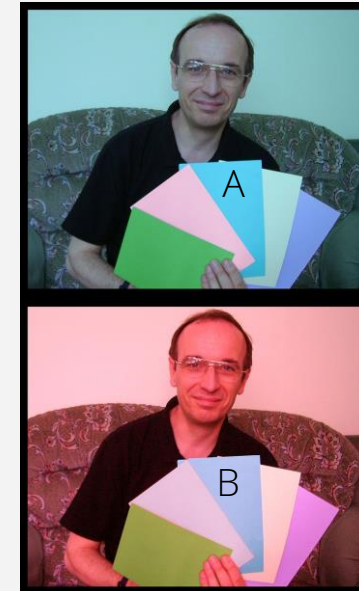

A and B are of the same color.



# CIE XYZ Color Space

---

- Proposed by the International Commission on Illumination CIE in 1931
- Motivated by trichromacy model
  - Three cone types  $\Leftrightarrow$  Three signals / numbers for a color
- Spectrum is converted to  $(X, Y, Z)$  with color-matching functions  $x(\lambda)$ ,  $y(\lambda)$ ,  $z(\lambda)$ .  
$$X = \int_{\lambda} L_{\lambda}(\lambda)x(\lambda)d\lambda \quad Y = \int_{\lambda} L_{\lambda}(\lambda)y(\lambda)d\lambda \quad Z = \int_{\lambda} L_{\lambda}(\lambda)z(\lambda)d\lambda$$
- Color-matching functions  $x(\lambda)$ ,  $y(\lambda)$ ,  $z(\lambda)$  have been experimentally estimated to map all perceivable colors to  $(X, Y, Z)$  values in the range from 0 to 1

# CIE xy Chromaticity Diagram

- XYZ represents color and brightness / luminance
- Two values are sufficient to represent color
$$x = \frac{X}{X+Y+Z} \quad y = \frac{Y}{X+Y+Z}$$
- Monochromatic colors are on the boundary
- The center is achromatic

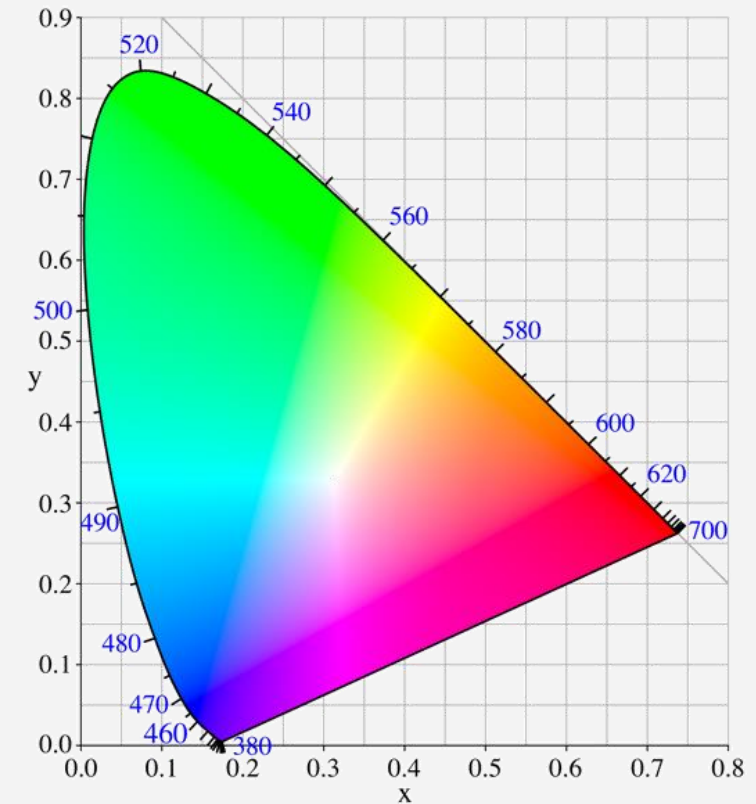

[Wikipedia: CIE 1931 color space]

# CIE RGB Color Space

- RGB color space

$$R = \int_{\lambda} L_{\lambda}(\lambda) r(\lambda) d\lambda$$

$$G = \int_{\lambda} L_{\lambda}(\lambda) g(\lambda) d\lambda$$

$$B = \int_{\lambda} L_{\lambda}(\lambda) b(\lambda) d\lambda$$

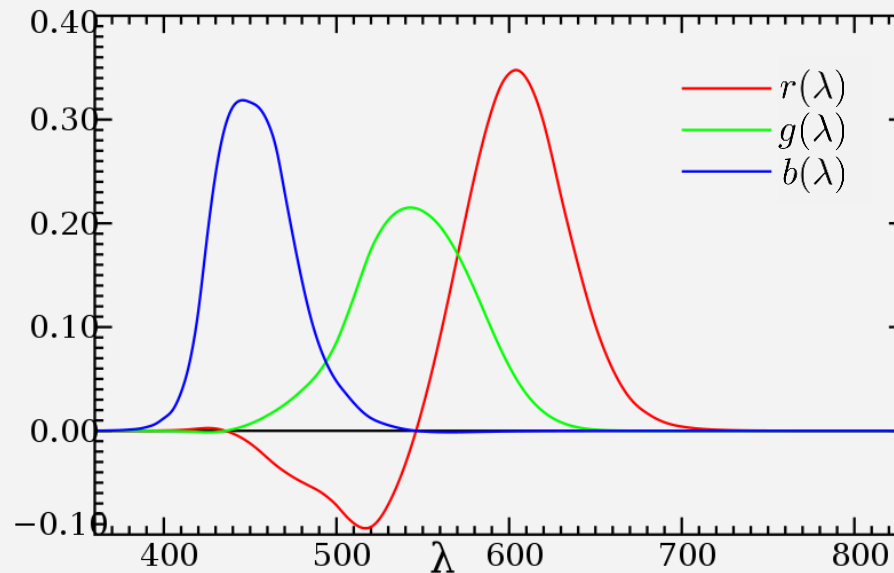

[Wikipedia:  
CIE 1931  
color space]

- Spectrum of  $L$  is converted to  $(R, G, B)$  given the color-matching functions  $r(\lambda)$ ,  $g(\lambda)$ ,  $b(\lambda)$
- The color-matching functions consider the spectra of **real display primaries** (e.g. LED, LCD, plasma cells)

# CIE RGB Color Space

- Different sets of primary colors result in different sets of color-matching functions  $r(\lambda)$ ,  $g(\lambda)$ ,  $b(\lambda)$

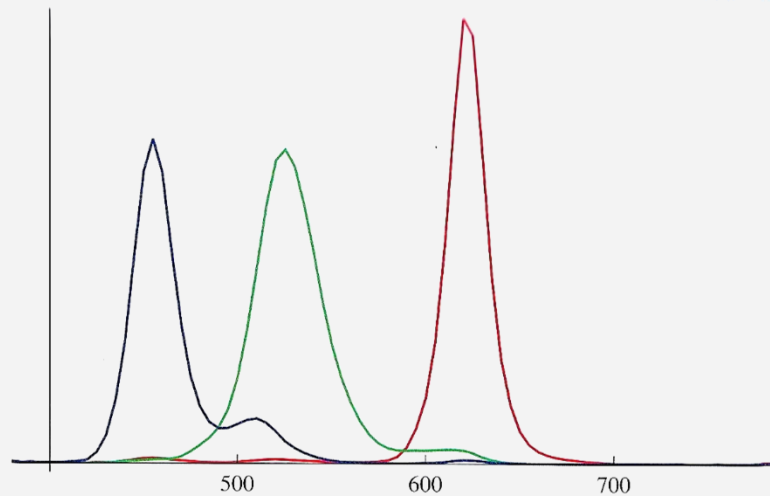

Spectra of red, green, blue  
for an LCD display

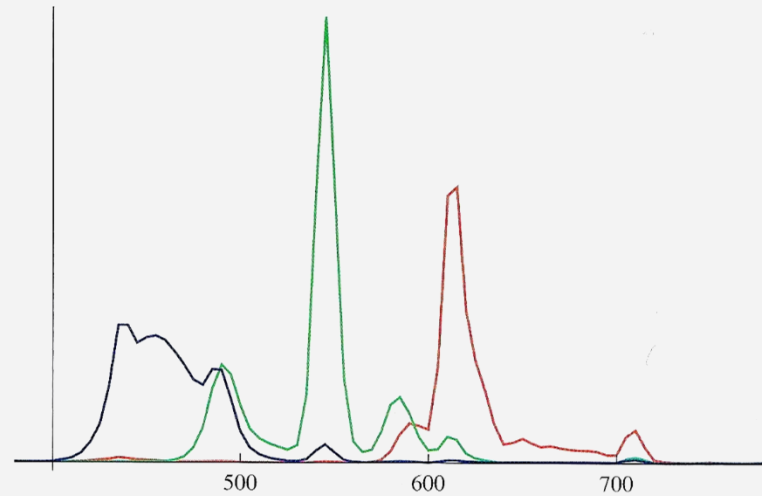

Spectra of red, green, blue  
for an LED display

[Pharr, Humphreys]

# Conversion XYZ / RGB

- Depends on the particular set of spectra of the primary display colors
- E.g., sRGB for HDTV

$$\begin{pmatrix} R \\ G \\ B \end{pmatrix} = \begin{pmatrix} 3.24 & -1.54 & -0.50 \\ -0.97 & 1.88 & 0.04 \\ 0.06 & -0.20 & 1.06 \end{pmatrix} \begin{pmatrix} X \\ Y \\ Z \end{pmatrix}$$

Negative matrix coefficients indicate that XYZ values could result in negative RGB values, i.e. *not all perceivable colors can be represented / generated with RGB.*

$$\begin{pmatrix} X \\ Y \\ Z \end{pmatrix} = \begin{pmatrix} 0.41 & 0.36 & 0.18 \\ 0.21 & 0.72 & 0.07 \\ 0.02 & 0.12 & 0.95 \end{pmatrix} \begin{pmatrix} R \\ G \\ B \end{pmatrix}$$

# Display Devices

- xy chromaticity diagram
- Three display / primary colors
  - Diagram indicates an example
- Can only reproduce colors within the spanned triangle (gamut)
- Colors outside the gamut are not properly displayed on the respective monitor

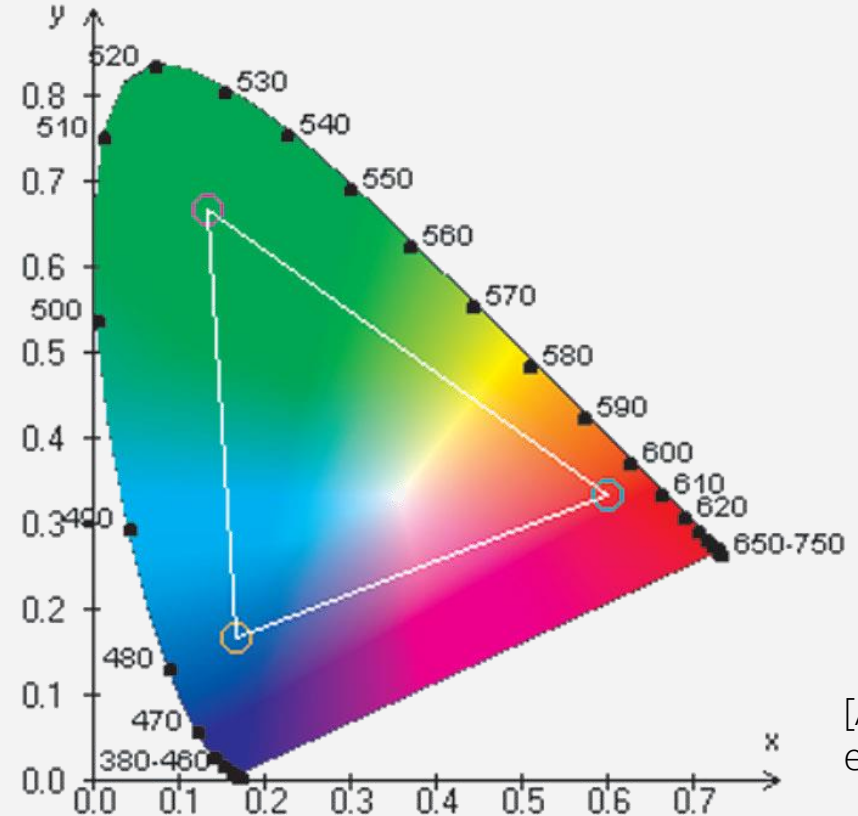

[Akenine-Möller et al.]

# RGB Color Space

- Three primaries: red, green, blue

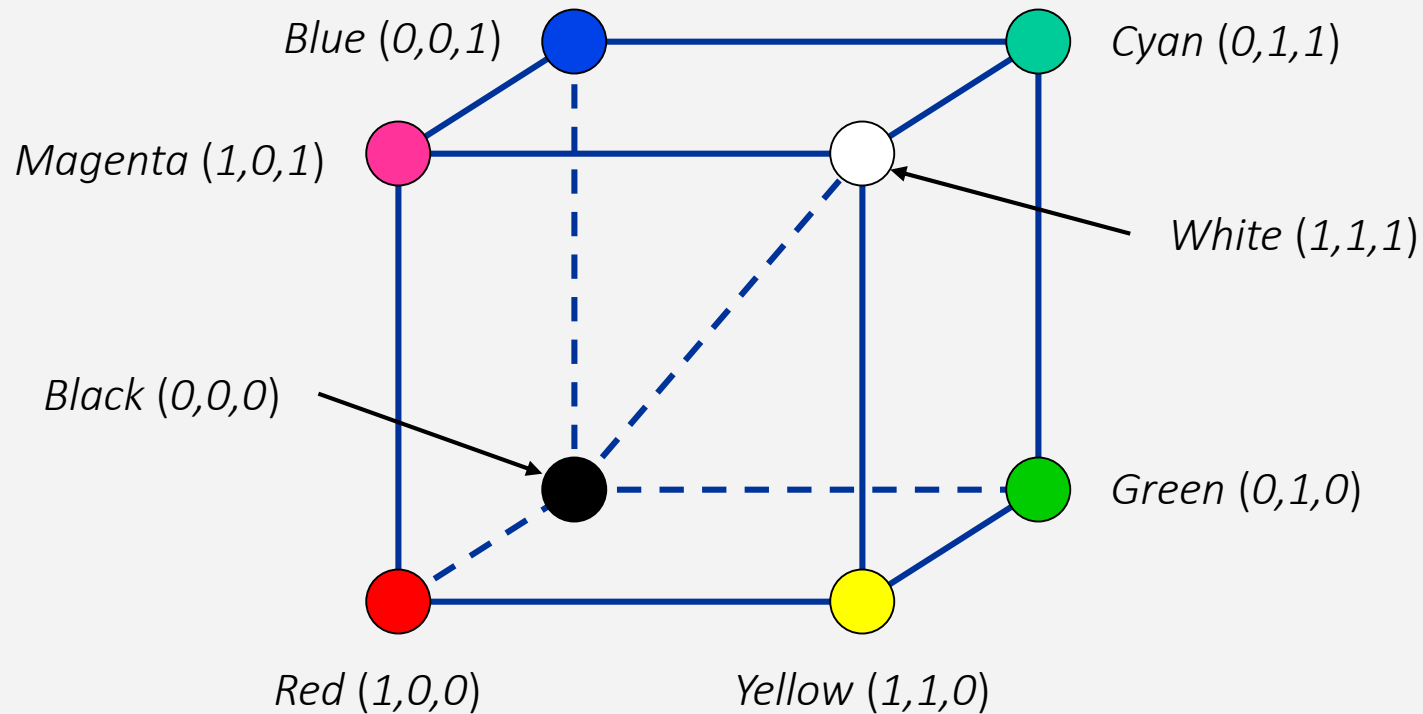

# *RGB Color Space - Flux*

---

- Light source color
  - E.g., yellow light (1, 1, 0)
  - Emits a spectrum with maximum red and green components
  - The spectrum does not contain any blue
  - The RGB values describe the amount of the respective color component in the emitted light



# RGB Color Space - Surfaces

---

- Surface color / reflectance
  - E.g., yellow object (1, 1, 0)
  - Perfectly reflects red and green components of the incoming light
  - Perfectly absorbs the blue component of the incoming light
  - The RGB values describe how much of the respective incoming color component is reflected ("one minus value" describes how much is absorbed)

# Summary

---

- Distribution of wavelengths within the perceived radiance is referred to as spectral power distribution or spectrum
- Spectra are weighted with absorption spectra of the eye and perceived as colors
- Three cone types for daylight vision motivate XYZ space
- XYZ space can represent all perceivable colors
- RGB space represents displayable colors
- Colors of display devices are restricted to a gamut that does not contain all perceivable colors
- Ray tracers can work with arbitrary representations
  - Conversion to RGB for display purposes